

INTRODUCTION OF MATERIAL SRIM 01(SF-1)

It's made of high quality low-carbon steel plate, sintered porous bronze as its interlayer and the compound of PTFE material and Pb as its surface. It offers the property of good self-lubricating, low wear and low friction, it has made full use of the strong points of metals and polymer materials. It is used in printing machines, woven machines, tobacco machines, as well as gymnastic machines etc.

PHYSICAL AND MECHANICAL PROPERTY

Performance index		Data
Load capacity P	Static load	250 N/mm ²
	Dynamic load	140 N/mm ²
Max line speed V	Dry friction	2.5m/s
	Oil lubrication	5m/s
PV value limit	Dry friction	3.6 N/ mm ² .m/s
	Oil lubrication	50 N/ mm ² .m/s
Friction coef μ	Dry friction	0.08 ~ 0.20
	Oil lubrication	0.02 ~ 0.07
Working temperature		-200°C ~ +280°C
Thermal conductivity		40 W/m · k
Coefficient of linear expansion		$12 \times 10^{-6}/K$

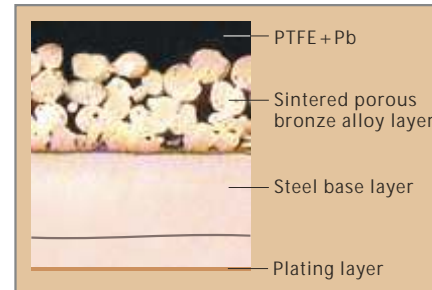

INTRODUCTION OF MATERIAL SRIM 01(SF-1B)

It's based on bronze alloy of a particular formulation with high density, with sintered bronze layer as its interlayer and the compound of PTFE material and Pb as its surface. It offers the property of good self-lubricating, low wear and low friction and has made full use of the strong points of metals and polymer materials. It's used in steel metallurgical industry, such as those used in roller grooves of successive casting machine, cement grout pumps and spiral conveyers for cement, etc.



PHYSICAL AND MECHANICAL PROPERTY

Performance index		Data
Load Capacity P	Static Load	250 N/mm ²
	Dynamic Load	140 N/mm ²
Max line speed V	Dry Friction	2m/s
	Oil Lubrication	5m/s
PV value limit	Dry Friction	3.6 N/ mm ² .m/s
	Oil Lubrication	50 N/ mm ² .m/s
Friction Coef μ	Dry friction	0.08~0.20
	Oil Lubrication	0.02~0.07
Working temperature		-200°C ~ +280°C
Thermal Conductivity		60 W/m · k
Coefficient of linear expansion		18 × 10 ⁻⁶ /K

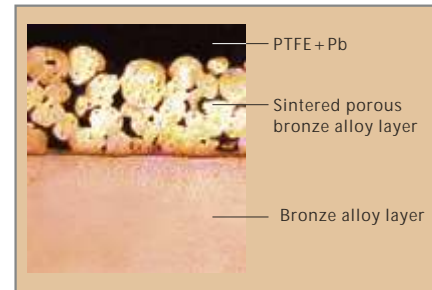

INTRODUCTION OF MATERIAL SRIM 01(SF-1S)

The material of this product is based on stainless steel base with sintered bronze layer as its interlayer and the compound of PTFE material and Pb as its surface. It can be used in the middle-acid & alkali and anti-corrosive parts of printing machines & oceanic industries.

PHYSICAL AND MECHANICAL PROPERTY

Performance index		Data
Load capacity P	Static load	250 N/mm ²
	Dynamic load	140 N/mm ²
Max line speed V	Dry friction	2 m/s
	Oil lubrication	5 m/s
PV value limit	Dry friction	3.6 N/ mm ² .m/s
	Oil lubrication	50 N/ mm ² .m/s
Friction coef μ	Dry friction	0.08~0.20
	Oil lubrication	0.02~0.07
Working temperature		-200°C ~ +280°C
Thermal conductivity		50 W/m · k
Coefficient of linear expansion		16 × 10 ⁻⁶ /K

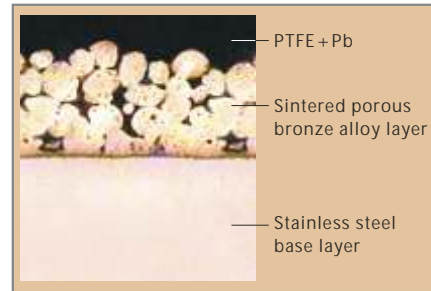

INTRODUCTION OF MATERIAL SRIM 01(SF-1T)

This material is specially applied for the high PV value of hydraulic oil pump. It is with low coefficient of friction and good wear-resistance. It can be used in the semi-dry environment. It is mainly applied in the middle, high pressure gear pump, ram pumps as well as vane pumps and soon.

PHYSICAL AND MECHANICAL PROPERTY

Performance index		Data
Load Capacity P	Static Load	250 N/mm ²
	Dynamic Load	140 N/mm ²
Max line speed V	Dry Friction	2 m/s
	Oil Lubrication	10 m/s
PV value limit	Dry Friction	3.8 N/ mm ² .m/s
	Oil Lubrication	60 N/ mm ² .m/s
Friction Coef μ	Dry friction	0.08 ~ 0.20
	Oil Lubrication	0.01 ~ 0.05
Working temperature		-200°C ~ +280°C
Thermal Conductivity		40 W/m · k
Coefficient of linear expansion		12 × 10 ⁻⁶ /K

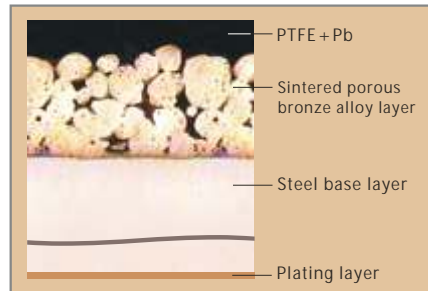

INTRODUCTION OF MATERIAL SRIM 01(SF-1P)

This material is specially designed according to the shock absorber's workmanship condition of reciprocating motion and lateral force. It is with low coefficient of friction and good wear-resistance and can be used in the semi-dry environment. It is mainly applied in the shock absorbers of automobiles & motorcycles, hydraulic and pneumatic cylinder etc.

PHYSICAL AND MECHANICAL PROPERTY

Performance index		Data
Load capacity P	Static load	250 N/mm ²
	Dynamic load	140 N/mm ²
Max line speed V	Dry friction	2 m/s
	Oil lubrication	5 m/s
PV value limit	Dry friction	3.8 N/ mm ² .m/s
	Oil lubrication	60 N/ mm ² .m/s
Friction coef μ	Dry friction	0.08 ~ 0.20
	Oil lubrication	0.01 ~ 0.05
Working temperature		-200°C ~ +280°C
Thermal conductivity		40 W/m · k
Coefficient of linear expansion		12 × 10 ⁻⁶ /K

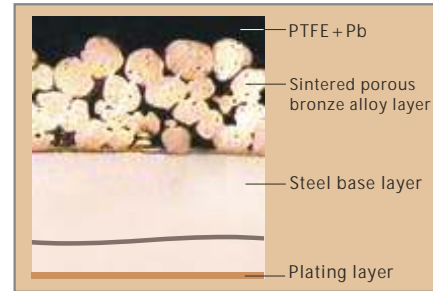
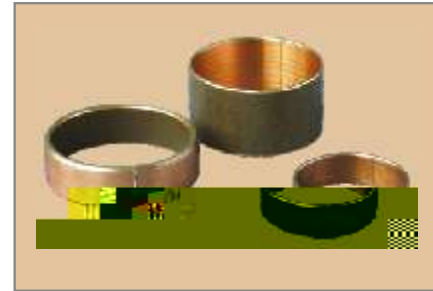

INTRODUCTION OF MATERIAL SRIM 015

The material of this product is based on stainless steel strip with sintered bronze layer as its interlayer and the compound of PTFE and other polymer as its surface. Due to without Pb, it makes the lubricating condition cleaner and meets the environment-protection requirements.

PHYSICAL AND MECHANICAL PROPERTY

Performance index		Data
Load Capacity P	Static Load	250 N/mm ²
	Dynamic Load	140 N/mm ²
Max line speed V	Dry Friction	2 m/s
	Oil Lubrication	5 m/s
PV value limit	Dry Friction	3.6 N/ mm ² .m/s
	Oil Lubrication	50 N/ mm ² .m/s
Friction Coef μ	Dry friction	0.08 ~ 0.22
	Oil Lubrication	0.02 ~ 0.07
Working temperature		-200°C ~ +280°C
Thermal Conductivity		40 W/m · k
Coefficient of linear expansion		12 × 10 ⁻⁶ /K

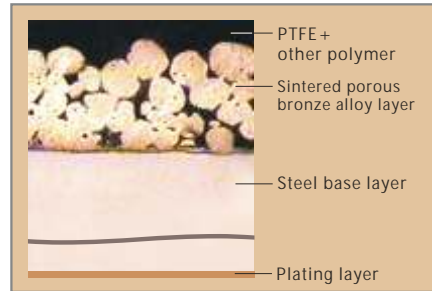

INTRODUCTION OF MATERIAL SRIM 016

The material of this product is based on bronze plate with sintered bronze layer as its interlayer and the compound of PTFE and other polymer as its surface. Due to without Pb, it makes the lubricating condition cleaner and meets the environment-protection requirements.

PHYSICAL AND MECHANICAL PROPERTY

Performance index		Data
Load capacity P	Static load	250 N/mm ²
	Dynamic load	140 N/mm ²
Max line speed V	Dry friction	2 m/s
	Oil lubrication	5 m/s
PV value limit	Dry friction	3.6 N/ mm ² .m/s
	Oil lubrication	50 N/ mm ² .m/s
Friction coef μ	Dry friction	0.08~0.22
	Oil lubrication	0.02~0.07
Working temperature		-200°C ~ +280°C
Thermal conductivity		60 W/m · k
Coefficient of linear expansion		18 × 10 ⁻⁶ /K

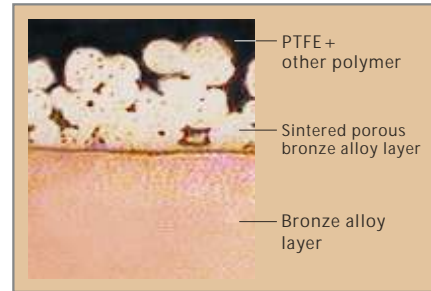

INTRODUCTION OF MATERIAL SRIM 017

The material of this product is based on stainless steel strip with sintered bronze layer as its interlayer and the compound of PTFE and other polymer as its surface. Due to without Pb, it makes the lubricating condition cleaner and meets the environment-protection requirements.

PHYSICAL AND MECHANICAL PROPERTY

Performance index		Data
Load Capacity P	Static Load	250 N/mm ²
	Dynamic Load	140 N/mm ²
Max line speed V	Dry Friction	2 m/s
	Oil Lubrication	5 m/s
PV value limit	Dry Friction	3.6 N/ mm ² .m/s
	Oil Lubrication	50 N/ mm ² .m/s
Friction Coef μ	Dry friction	0.08~0.22
	Oil Lubrication	0.02~0.07
Working temperature		-200°C ~ +280°C
Thermal Conductivity		50 W/m · k
Coefficient of linear expansion		16 × 10 ⁻⁶ /K

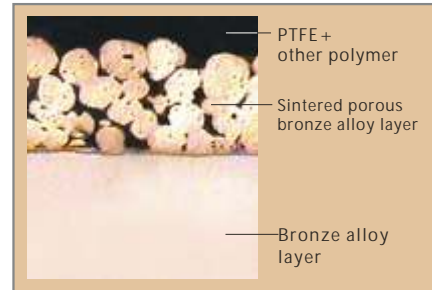

INTRODUCTION OF MATERIAL SRIM 018

This material is specially applied in the high PV value of hydraulic pressure oil pump. It is with low coefficient of friction and good wear-resistance. It can be used in the semi-dry environment. It is mainly applied in the middle, high pressure gear pump, ram pumps as well as vane pumps and so on. Due to without Pb, it makes the lubricating condition cleaner and meets the environment-protection requirements.

PHYSICAL AND MECHANICAL PROPERTY

Performance index		Data
Load capacity P	Static load	250 N/mm ²
	Dynamic load	140 N/mm ²
Max line speed V	Dry friction	2 m/s
	Oil lubrication	10 m/s
PV value limit	Dry friction	3.8 N/ mm ² .m/s
	Oil lubrication	60 N/ mm ² .m/s
Friction coef μ	Dry friction	0.08 ~ 0.20
	Oil lubrication	0.02 ~ 0.06
Working temperature		-200°C ~ +280°C
Thermal conductivity		40 W/m · k
Coefficient of linear expansion		$12 \times 10^{-6} / K$

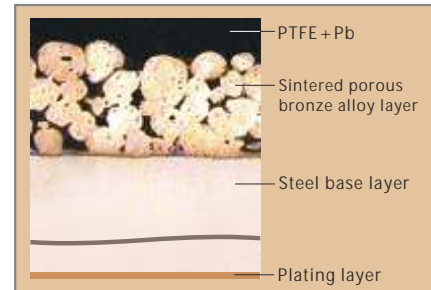

INTRODUCTION OF MATERIAL SRIM 019

This material is specially designed according to the shock absorber's workmanship condition of the reciprocating motion and lateral force. It is with low coefficient of friction and good wear-resistance and can be used in the semi-dry environment. It is mainly applied in the shock absorbers of automobiles & motorcycles, hydraulic and pneumatic cylinder etc. Due to without Pb, it makes the lubricating condition cleaner and meets the environment-protection requirements.

PHYSICAL AND MECHANICAL PROPERTY

Performance index		Data
Load capacity P	Static load	250 N/mm ²
	Dynamic load	140 N/mm ²
Max line speed V	Dry friction	2 m/s
	Oil lubrication	5 m/s
PV value limit	Dry friction	3.6 N/ mm ² .m/s
	Oil lubrication	60 N/ mm ² .m/s
Friction coef μ	Dry friction	0.08 ~ 0.20
	Oil lubrication	0.01 ~ 0.05
Working temperature		-200°C ~ + 280°C
Thermal conductivity		40 W/m · k
Coefficient of linear expansion		$12 \times 10^{-6} /K$

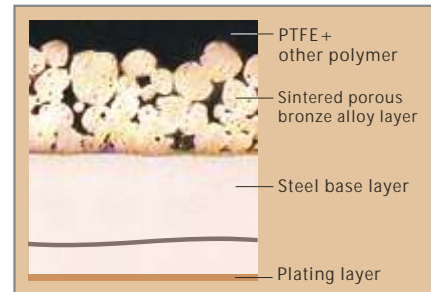

BUSHING O.D. AND SUITABLE SHAFT, HOUSING BORE TOLERANCES TABLE

BASIC DIMENSION	O.D. DIMENSION	SUITABLE HOUSING BORE D_H	SUITABLE SHAFT d_j
~ 3	—	—	0 -0.006
3 ~ 6	+0.055 +0.025	+0.008 0	0 -0.008
6 ~ 10		+0.015 0	-0.013 -0.028
10 ~ 18	+0.065 +0.030	+0.018 0	-0.016 -0.034
18 ~ 30	+0.075 +0.035	+0.021 0	-0.020 -0.041
30 ~ 50	+0.085 +0.045	+0.025 0	-0.025 -0.050
50 ~ 75			-0.030 -0.060
75 ~ 80	+0.100 +0.055	+0.030 0	0 -0.046
80 ~ 120	+0.120 +0.070	+0.035 0	0 -0.054
120 ~ 180	+0.170 +0.100	+0.040 0	0 -0.063
180 ~ 250	+0.210 +0.130	+0.046 0	0 -0.072
250 ~ 315	+0.260 +0.170	+0.052 0	0 -0.081

WALL THICKNESS TOLERANCES AND INSIDE, OUTSIDE CHAMFER TABLE

BASIC DIMENSION d	WALL THICKNESS TOLERANCES S_B	CHAMFER DIMENSION	
		f1	f2
~ 2	0.75 ^{+0.005} -0.025	Max.0.3	Max.0.3
2 ~ 4	0.75 ⁰ -0.02		
4 ~ 20	1 ^{+0.005} -0.020	0.6 ± 0.4	Max.0.4
20 ~ 25	1.5 ^{+0.005} -0.025	0.6 ± 0.4	0.4 ± 0.3
25 ~ 40	2 ^{+0.005} -0.030	1.2 ± 0.4	0.4 ± 0.3
40 ~ 75	2.5 ^{+0.005} -0.040	1.8 ± 0.6	0.6 ± 0.4
75 ~ 110	2.5 ^{-0.010} -0.060		
110 ~ 300	2.5 ^{-0.035} -0.085		

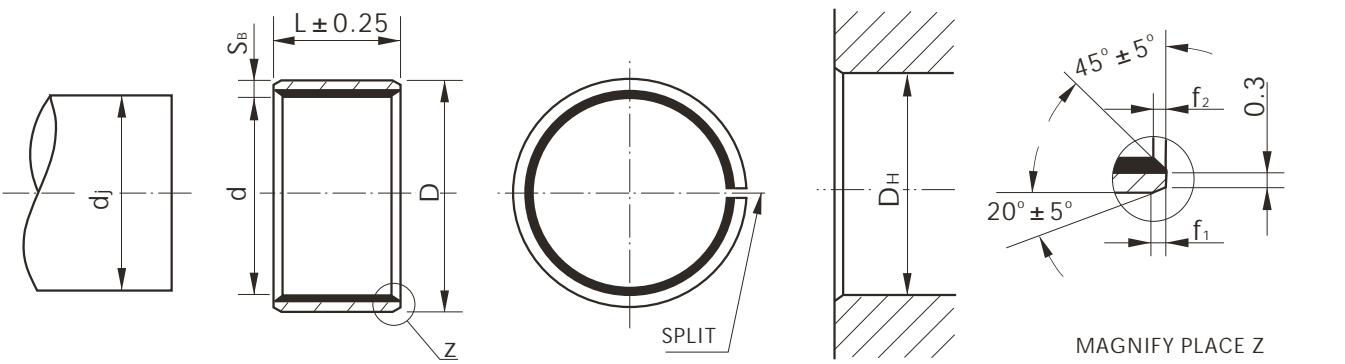

DESIGNATION	d	D	L
SRIM 01 0203		3.5	3
SRIM 01 0205	2		5
SRIM 01 0303			3
SRIM 01 0305	3	4.5	5
SRIM 01 0306			6
SRIM 01 0403			3
SRIM 01 0404			4
SRIM 01 0406	4	5.5	6
SRIM 01 0410			10
SRIM 01 0505			5
SRIM 01 0508	5	7	8
SRIM 01 0510			10
SRIM 01 0604			4
SRIM 01 0606			6
SRIM 01 0608	6	8	8
SRIM 01 0610			10
SRIM 01 0710	7	9	10
SRIM 01 0806			6
SRIM 01 0808			8
SRIM 01 0810	8	10	10
SRIM 01 0812			12
SRIM 01 1008			8
SRIM 01 1010			10
SRIM 01 1012	10	12	12
SRIM 01 1015			15
SRIM 01 1020			20
SRIM 01 1208			8
SRIM 01 1210			10
SRIM 01 1212			12
SRIM 01 1215	12	14	15
SRIM 01 1220			20
SRIM 01 1225			25
SRIM 01 1310			10
SRIM 01 1320	13	15	20
SRIM 01 1405	14	16	5

Unit:mm

DESIGNATION	d	D	L
SRIM 01 1410			10
SRIM 01 1412			12
SRIM 01 1415	14	16	15
SRIM 01 1420			20
SRIM 01 1425			25
SRIM 01 1510			10
SRIM 01 1512			12
SRIM 01 1515	15	17	15
SRIM 01 1520			20
SRIM 01 1525			25
SRIM 01 1610			10
SRIM 01 1612			12
SRIM 01 1615	16	18	15
SRIM 01 1620			20
SRIM 01 1625			25
SRIM 01 1712			12
SRIM 01 1720	17	19	20
SRIM 01 1810			10
SRIM 01 1815			15
SRIM 01 1820	18	20	20
SRIM 01 1825			25
SRIM 01 2010			10
SRIM 01 2015			15
SRIM 01 2020	20	23	20
SRIM 01 2025			25
SRIM 01 2030			30
SRIM 01 2215			15
SRIM 01 2220			20
SRIM 01 2225	22	25	25
SRIM 01 2230			30
SRIM 01 2415			15
SRIM 01 2420			20
SRIM 01 2425	24	27	25
SRIM 01 2430			30
SRIM 01 2515	25	28	15

DESIGNATION		d	D	L	DESIGNATION		d	D	L
SRIM 01	2520			20	COB 01	6550			50
SRIM 01	2525			25	SRIM 01	6570	65	70	70
SRIM 01	2530	25	28	30	SRIM 01	7040			40
SRIM 01	2540			40	SRIM 01	7050	70	75	50
SRIM 01	2550			50	SRIM 01	7070			70
SRIM 01	2815			15	SRIM 01	7550			50
SRIM 01	2820	28	32	20	SRIM 01	7560	75	80	60
SRIM 01	2825			25	SRIM 01	7580			80
SRIM 01	2830			30	SRIM 01	8060			60
SRIM 01	3010			10	SRIM 01	80100	80	85	100
SRIM 01	3015			15	SRIM 01	8530			30
SRIM 01	3020	30	34	20	SRIM 01	8560	85	90	60
SRIM 01	3025			25	SRIM 01	85100			100
SRIM 01	3030			30	SRIM 01	9060			60
SRIM 01	3040			40	SRIM 01	90100	90	95	100
SRIM 01	3220			20	SRIM 01	9560			60
SRIM 01	3230	32	36	30	SRIM 01	95100	95	100	100
SRIM 01	3240			40	SRIM 01	10050			50
SRIM 01	3520			20	SRIM 01	10060			60
SRIM 01	3530			30	SRIM 01	100115	100	105	115
SRIM 01	3535	35	39	35	SRIM 01	10560			60
SRIM 01	3540			40	SRIM 01	105115	105	110	115
SRIM 01	3550			50	SRIM 01	11060			60
SRIM 01	3720	37	41	20	SRIM 01	110115	110	115	115
SRIM 01	4020			20	SRIM 01	11550			50
SRIM 01	4030	40	44	30	SRIM 01	11570	115	120	70
SRIM 01	4040			40	SRIM 01	12050			50
SRIM 01	4050			50	SRIM 01	12060			60
SRIM 01	4520			20	SRIM 01	120100	120	125	100
SRIM 01	4530			30	SRIM 01	120120			120
SRIM 01	4540	45	50	40	SRIM 01	125100	125	130	100
SRIM 01	4545			45	SRIM 01	13060			60
SRIM 01	4550			50	SRIM 01	130100	130	135	100
SRIM 01	5020			20	SRIM 01	13560			60
SRIM 01	5030			30	SRIM 01	13580	135	140	80
SRIM 01	5040	50	55	40	SRIM 01	14060			60
SRIM 01	5050			50	SRIM 01	140100	140	145	100
SRIM 01	5060			60	SRIM 01	140120			120
SRIM 01	5520			20	SRIM 01	15060			60
SRIM 01	5525			25	SRIM 01	15080	150	155	80
SRIM 01	5530			30	SRIM 01	150100			100
SRIM 01	5540	55	60	40	SRIM 01	16080			80
SRIM 01	5550			50	SRIM 01	160100	160	165	100
SRIM 01	5555			55	SRIM 01	18080			80
SRIM 01	5560			60	SRIM 01	180100	180	185	100
SRIM 01	6020			20	SRIM 01	200100	200	205	100
SRIM 01	6030			30	SRIM 01	210100	210	215	100
SRIM 01	6040	60	65	40	SRIM 01	220100	220	225	100
SRIM 01	6050			50	SRIM 01	250100	250	255	100
SRIM 01	6060			60	SRIM 01	28080	280	285	80
SRIM 01	6070			70	SRIM 01	300100	300	305	100
SRIM 01	6530	65	70	30					

BUSHING O.D. AND SUITABLE SHAFT, HOUSING BORE TOLERANCES TABLE

BASIC DIMENSION	O.D. DIMENSION	SUITABLE HOUSING BORE D_H	SUITABLE SHAFT d_j
~ 3	—	—	0 -0.006
3 ~ 6	+0.055 +0.025	+0.008 0	0 -0.008
6 ~ 10	+0.065 +0.030	+0.015 0	-0.013 -0.028
10 ~ 18	+0.075 +0.035	+0.021 0	-0.020 -0.041
18 ~ 30	+0.085 +0.045	+0.025 0	-0.025 -0.050
30 ~ 50			

WALL THICKNESS TOLERANCES AND INSIDE , OUTSIDE CHAMFER TABLE

BASIC DIMENSION d	WALL THICKNESS TOLERANCES		CHAMFER DIMENSION	
	S_B	b	f_1	f_2
~ 4	$0.8 \begin{smallmatrix} 0 \\ -0.025 \end{smallmatrix}$	$0.8 \begin{smallmatrix} +0.15 \\ -0.15 \end{smallmatrix}$	Max.0.3	Max.0.3
4 ~ 18	$1 \begin{smallmatrix} +0.005 \\ -0.020 \end{smallmatrix}$	$1 \begin{smallmatrix} +0.05 \\ -0.05 \end{smallmatrix}$	0.6 ± 0.4	Max.0.4
18 ~ 25	$1.5 \begin{smallmatrix} +0.005 \\ -0.020 \end{smallmatrix}$	$1.5 \begin{smallmatrix} +0.1 \\ -0.1 \end{smallmatrix}$	0.6 ± 0.4	0.4 ± 0.3
25 ~ 40	$2 \begin{smallmatrix} +0.005 \\ -0.030 \end{smallmatrix}$	$2 \begin{smallmatrix} +0.1 \\ -0.1 \end{smallmatrix}$	1.2 ± 0.4	0.4 ± 0.3
40 ~ 45	$2.5 \begin{smallmatrix} +0.005 \\ -0.040 \end{smallmatrix}$	$2.5 \begin{smallmatrix} +0.1 \\ -0.1 \end{smallmatrix}$	1.8 ± 0.6	0.6 ± 0.4

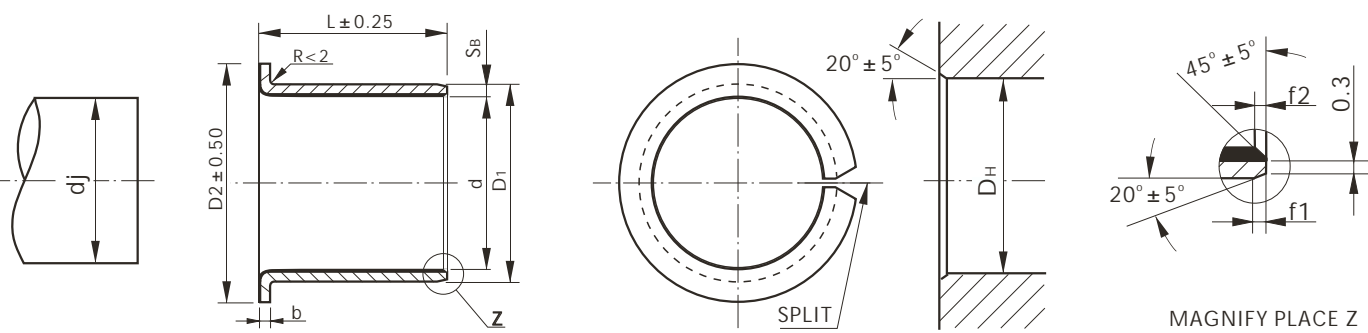

MAGNIFY PLACE Z

Unit:mm

DESIGNATION	d	D ₁	D ₂	L
SRIM 01 F 0304	3	4.6	7	4
SRIM 01 F 0405	4	5.6	9	5
SRIM 01 F 0505	5	7	10	5
SRIM 01 F 0604				4
SRIM 01 F 0607	6	8	12	7
SRIM 01 F 0608				8
SRIM 01 F 0805.5				5.5
SRIM 01 F 0806				6
SRIM 01 F 0807.5	8	10	15	7.5
SRIM 01 F 0808				8
SRIM 01 F 0809.5				9.5
SRIM 01 F 0810				10
SRIM 01 F 1007				7
SRIM 01 F 1009	10	12	18	9
SRIM 01 F 1012				12
SRIM 01 F 1017				17
SRIM 01 F 1207				7
SRIM 01 F 1209				9
SRIM 01 F 1212	12	14	20	12
SRIM 01 F 1215				15
SRIM 01 F 1217				17
SRIM 01 F 1412	14	16	22	12
SRIM 01 F 1417				17
SRIM 01 F 1509				9
SRIM 01 F 1512	15	17	23	12
SRIM 01 F 1517				17

DESIGNATION	d	D ₁	D ₂	L
SRIM 01 F 1612	16	18	24	12
SRIM 01 F 1617				17
SRIM 01 F 1812				12
SRIM 01 F 1817	18	20	26	17
SRIM 01 F 1822				22
SRIM 01 F 2011.5				11.5
SRIM 01 F 2012				12
SRIM 01 F 2015				15
SRIM 01 F 2016.5	20	23	30	16.5
SRIM 01 F 2017				17
SRIM 01 F 2021.5				21.5
SRIM 01 F 2022				22
SRIM 01 F 2511.5				11.5
SRIM 01 F 2512				12
SRIM 01 F 2516.5	25	28	35	16.5
SRIM 01 F 2517				17
SRIM 01 F 2521.5				21.5
SRIM 01 F 2522				22
SRIM 01 F 3016	30	34	42	16
SRIM 01 F 3026				26
SRIM 01 F 3516	35	39	47	16
SRIM 01 F 3526				26
SRIM 01 F 4016	40	44	53	16
SRIM 01 F 4026				26
SRIM 01 F 4516	45	50	58	16
SRIM 01 F 4526				26

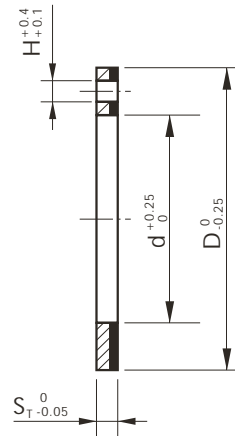
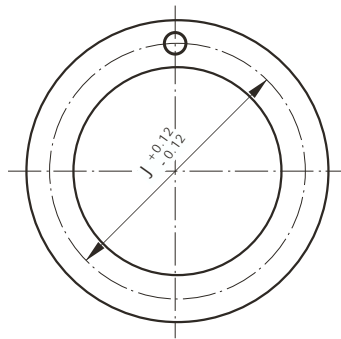

Unit:mm

DESIGNATION	$d^{+0.25}_0$	$D^0_{-0.25}$	$S_T^0_{-0.05}$	$J^{+0.12}_{-0.12}$	$H^{+0.4}_{+0.1}$
SRIM 01 W 10	10	20	1.5	15	1.5
SRIM 01 W 12	12	24		18	
SRIM 01 W 14	14	26		20	
SRIM 01 W 16	16	30		22	2
SRIM 01 W 18	18	32		25	
SRIM 01 W 20	20	36	1.5	28	3
SRIM 01 W 22	22	38		30	
SRIM 01 W 26	26	44		35	
SRIM 01 W 28	28	48	2	38	4
SRIM 01 W 32	32	54		43	
SRIM 01 W 38	38	62		50	
SRIM 01 W 42	42	66		54	
SRIM 01 W 48	48	74	2	61	4
SRIM 01 W 52	52	78		65	
SRIM 01 W 62	62	90		76	

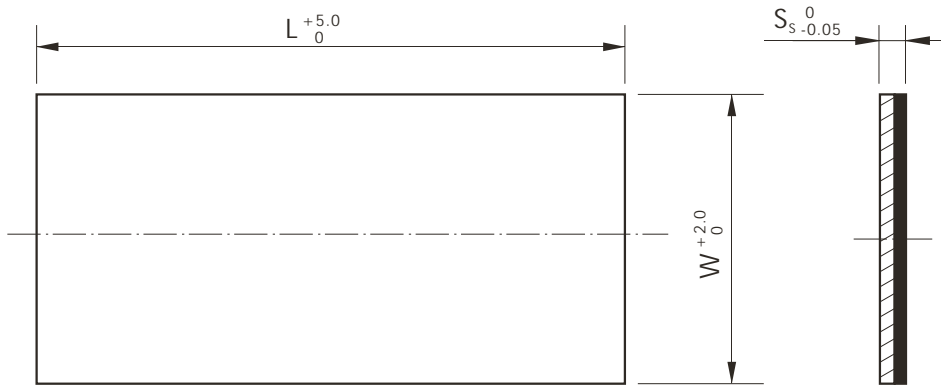

Unit:mm

DESIGNATION	L $^{+5.0}$ ₀	W $^{+2.0}$ ₀	S 0 _{-0.05}
SRIM 01 P 075125			0.75
SRIM 01 P 100125			1
SRIM 01 P 150125			1.5
SRIM 01 P 200125	500	125	2
SRIM 01 P 250125			2.5
SRIM 01 P 300125			3

SUITABLE SHAFT, HOUSING BORE TOLERANCE TABLE

BASIC DIMENSION d	SUITABLE HOUSING BORE DH	SUITABLE SHAFT dj
1/8	0.1873 0.1878	0.1243 0.1236
5/32	0.2186 0.2191	0.1554 0.1547
3/16	0.2497 0.2503	0.1865 0.1858
1/4	0.3122 0.3128	0.2490 0.2481
5/16	0.3747 0.3753	0.3115 0.3106
3/8	0.4684 0.4691	0.3740 0.3731
7/16	0.5309 0.5316	0.4365 0.4355
1/2	0.5934 0.5941	0.4990 0.4980
9/16	0.6559 0.6566	0.5615 0.5605
5/8	0.7184 0.7192	0.6240 0.6230
11/16	0.7809 0.7817	0.6865 0.6855
3/4	0.8747 0.8755	0.7491 0.7479
13/16	0.9372 0.9380	0.8116 0.8104
7/8	0.9997 1.0005	0.8741 0.8729
1	1.1246 1.1256	0.9991 0.9979
1 1/8	1.2808 1.2818	1.1238 1.1226
1 1/4	1.4058 1.4068	1.2488 1.2472
1 3/8	1.5308 1.5318	1.3738 1.3722
1 1/2	1.6558 1.6568	1.4988 1.4972
1 5/8	1.7808 1.7818	1.6238 1.6222
1 3/4	1.9371 1.9381	1.7487 1.7471
1 7/8	2.0621 2.0633	1.8737 1.8721
2	2.1871 2.1883	1.9987 1.9969
2 1/8	2.3118 2.3130	2.1257 2.1239

BASIC DIMENSION d	SUITABLE HOUSING BORE DH	SUITABLE SHAFT dj
2 1/4	2.4365 2.4377	2.2507 2.2489
2 1/2	2.6869 2.6881	2.5011 2.4993
2 3/4	2.9358 2.9370	2.7500 2.7482
2 7/8	3.0610 3.0623	2.8752 2.8734
3	3.1858 3.1872	3.0000 2.9982
3 1/4	3.4358 3.4372	3.2500 3.2480
3 1/2	3.6858 3.6872	3.5000 3.4978
3 5/8	3.8108 3.8122	3.6250 3.6228
3 3/4	3.9358 3.9372	3.7500 3.7478
4	4.1858 4.1872	4.0000 3.9978
4 1/4	4.4358 4.4372	4.2500 4.2478
4 3/8	4.5608 4.5622	4.3750 4.3728
4 1/2	4.6858 4.6872	4.5000 4.4978
4 3/4	4.9358 4.9374	4.7500 4.7475
5	5.1844 5.1860	4.9986 4.9961
5 1/4	5.4358 5.4374	5.2500 5.2475
5 1/5	5.6858 5.6874	6.0000 5.9975
5 3/4	5.9358 5.9374	5.5000 5.4975
6	6.1858 6.1874	6.2500 6.2475
6 1/4	6.4358 6.4374	6.5000 6.4975
6 1/2	6.6858 6.6874	6.5000 6.4975
6 3/4	6.9358 6.9374	6.7500 6.7475
7	7.1812 7.1830	6.9954 6.9929

WALL THICKNESS TOLERANCES AND INSIDE, OUTSIDE CHAMFER TABLE

BASIC DIMENSION d	WALL THICKNESS TOLERANCES S _B	CHAMFER DIMENSION	
		f1	f2
5/16	0.0315 0.0305	Max.0.0118	Max.0.0118
5/16 ~ 11/16	0.0471 0.0461	0.0394 0.0079	Max.0.0157
11/16 ~ 1	0.0627 0.0615	0.0394 0.0079	0.0079 0.0039
1 ~ 1 5/8	0.0784 0.0770	0.0630 0.0315	0.0276 0.0039
1 5/8 ~ 2	0.0941 0.0923	0.0945	0.0394
2 ~ 7	0.0928 0.0902	0.0472	0.0079

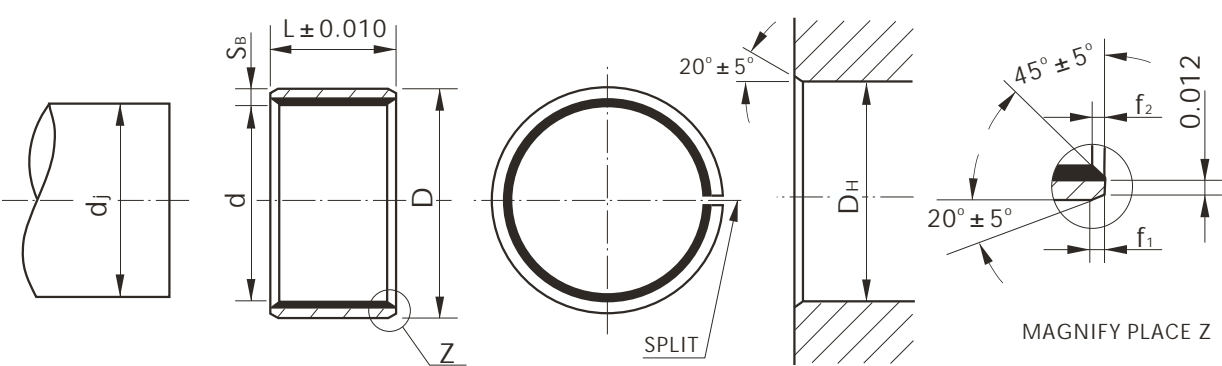

Unit:inch

DESIGNATION	d	D	L
SRIM 01 02Y02	1/8	3/16	1/8
SRIM 01 02Y03			3/16
SRIM 01 025Y025	5/32	7/32	5/32
SRIM 01 025Y04			1/4
SRIM 01 03Y03			3/16
SRIM 01 03Y04	3/16	1/4	1/4
SRIM 01 03Y06			3/8
SRIM 01 04Y04	1/4	5/16	1/4
SRIM 01 04Y06			3/8
SRIM 01 05Y06	5/16	5/8	3/8
SRIM 01 05Y08			1/2
SRIM 01 06Y03			3/16
SRIM 01 06Y04			1/4
SRIM 01 06Y06	3/8	15/32	3/8
SRIM 01 06Y08			1/2
SRIM 01 06Y10			5/8
SRIM 01 06Y12			3/4
SRIM 01 07Y08	7/16	19/32	1/2
SRIM 01 07Y12			3/4
SRIM 01 08Y04			1/4
SRIM 01 08Y06			3/8
SRIM 01 08Y08			1/2
SRIM 01 08Y10	1/2	21/32	5/8
SRIM 01 08Y12			3/4
SRIM 01 08Y14			7/8
SRIM 01 09Y06			3/8
SRIM 01 09Y08			1/2
SRIM 01 09Y10	9/16	21/32	5/8
SRIM 01 09Y12			3/4
SRIM 01 10Y04			1/4
SRIM 01 10Y08	5/8	23/32	1/2

DESIGNATION	d	D	L
SRIM01 10Y10			5/8
SRIM 01 10Y12			3/4
SRIM 01 10Y14	5/8	23/32	7/8
SRIM 01 10Y16			1
SRIM 01 11Y14	11/16	25/32	7/8
SRIM 01 12Y04			1/4
SRIM 01 12Y06			3/8
SRIM 01 12Y08			1/2
SRIM 01 12Y10	3/4	7/8	5/8
SRIM 01 12Y12			3/4
SRIM 01 12Y16			1
SRIM 01 13Y12			3/4
SRIM 01 13Y18	13/16	15/16	1/8
SRIM 01 14Y04			1/4
SRIM 01 14Y06			3/8
SRIM 01 14Y12	7/8	1	3/4
SRIM 01 14Y14			7/8
SRIM 01 14Y16			1
SRIM 01 14Y20			1 1/4
SRIM 01 16Y06			3/8
SRIM 01 16Y08			1/2
SRIM 01 16Y12			3/4
SRIM 01 16Y16	1	1 1/8	1
SRIM 01 16Y20			1 1/4
SRIM 01 16Y24			1 1/2
SRIM 01 18Y06			3/8
SRIM 01 18Y10			5/8
SRIM 01 18Y12	1 1/8	1 9/32	3/4
SRIM 01 18Y16			1
SRIM 01 20Y06			3/8
SRIM 01 20Y12	1 1/4	1 13/32	3/4

DESIGNATION	d	D	L
SRIM 01 20Y14			$\frac{7}{8}$
SRIM 01 20Y16	$1\frac{1}{4}$	1^{13}_{32}	1
SRIM 01 20Y20			$1\frac{1}{4}$
SRIM 01 20Y28			$1\frac{3}{4}$
SRIM 01 22Y12			$\frac{3}{4}$
SRIM 01 22Y16			1
SRIM 01 22Y22	$1\frac{3}{8}$	1^{17}_{32}	$1\frac{3}{8}$
SRIM 01 22Y24			$1\frac{1}{2}$
SRIM 01 22Y28			$1\frac{3}{4}$
SRIM 01 24Y08			$\frac{1}{2}$
SRIM 01 24Y16			1
SRIM 01 24Y18	$1\frac{1}{2}$	1^{21}_{32}	$1\frac{1}{8}$
SRIM 01 24Y20			$1\frac{1}{4}$
SRIM 01 24Y24			$1\frac{1}{2}$
SRIM 01 24Y32			2
SRIM 01 26Y16	$1\frac{5}{8}$	1^{25}_{32}	1
SRIM 01 26Y24			$1\frac{1}{2}$
SRIM 01 28Y16			1
SRIM 01 28Y24	$1\frac{3}{4}$	1^{15}_{16}	$1\frac{1}{2}$
SRIM 01 28Y28			$1\frac{3}{4}$
SRIM 01 28Y32			2
SRIM 01 30Y12			$\frac{3}{4}$
SRIM 01 30Y16	$1\frac{7}{8}$	$2\frac{1}{16}$	1
SRIM 01 30Y30			$1\frac{7}{8}$
SRIM 01 30Y36			$2\frac{1}{4}$
SRIM 01 32Y08			$\frac{1}{2}$
SRIM 01 32Y16			1
SRIM 01 32Y24	2	$2\frac{3}{16}$	$1\frac{1}{2}$
SRIM 01 32Y28			$1\frac{3}{4}$
SRIM 01 32Y32			2
SRIM 01 32Y40			$2\frac{1}{2}$
SRIM 01 34Y48	$2\frac{1}{8}$	$2\frac{5}{16}$	3
SRIM 01 36Y28			$1\frac{3}{4}$
SRIM 01 36Y32			
SRIM 01 36Y40			$2\frac{1}{2}$
SRIM 01 36Y48	$2\frac{1}{4}$	$2\frac{7}{16}$	3
SRIM 01 36Y56			$3\frac{1}{2}$
SRIM 01 36Y60			$3\frac{3}{4}$
SRIM 01 36Y64			4
SRIM 01 36Y72			$4\frac{1}{4}$
SRIM 01 40Y16			1
SRIM 01 40Y26	$2\frac{1}{2}$	2^{11}_{16}	$1\frac{5}{8}$
SRIM 01 40Y32			2
SRIM 01 40Y40			$2\frac{1}{2}$

DESIGNATION	d	D	L
SRIM 01 40Y48			3
SRIM 01 40Y56			$3\frac{1}{2}$
SRIM 01 40Y60	$2\frac{1}{2}$	2^{11}_{16}	$3\frac{3}{4}$
SRIM 01 40Y64			4
SRIM 01 40Y72			$4\frac{1}{2}$
SRIM 01 40Y76			$4\frac{3}{4}$
SRIM 01 44Y32			2
SRIM 01 44Y36			$2\frac{1}{4}$
SRIM 01 44Y40			$2\frac{1}{2}$
SRIM 01 44Y48			3
SRIM 01 44Y56	$2\frac{3}{4}$	2^{15}_{16}	$3\frac{1}{2}$
SRIM 01 44Y60			$3\frac{3}{4}$
SRIM 01 44Y64			4
SRIM 01 44Y72			$4\frac{1}{2}$
SRIM 01 44Y76			$4\frac{3}{4}$
SRIM 01 44Y80			5
SRIM 01 46Y32			2
SRIM 01 46Y36			$2\frac{1}{4}$
SRIM 01 46Y40			$2\frac{1}{2}$
SRIM 01 46Y48			3
SRIM 01 46Y56	$2\frac{7}{8}$	$3\frac{1}{16}$	$3\frac{1}{2}$
SRIM 01 46Y60			$3\frac{3}{4}$
SRIM 01 46Y64			4
SRIM 01 46Y72			$4\frac{1}{2}$
SRIM 01 46Y76			$4\frac{3}{4}$
SRIM 01 46Y80			5
SRIM 01 48Y32			2
SRIM 01 48Y36			$2\frac{1}{4}$
SRIM 01 48Y40			$2\frac{1}{2}$
SRIM 01 48Y48			3
SRIM 01 48Y56	3	$3\frac{3}{16}$	$3\frac{1}{2}$
SRIM 01 48Y60			$3\frac{3}{4}$
SRIM 01 48Y64			4
SRIM 01 48Y72			$4\frac{1}{2}$
SRIM 01 48Y76			$4\frac{3}{4}$
SRIM 01 48Y80			5
SRIM 01 52Y32			2
SRIM 01 52Y38			$2\frac{3}{8}$
SRIM 01 52Y40			$2\frac{1}{2}$
SRIM 01 52Y48	$3\frac{1}{4}$	$3\frac{7}{16}$	3
SRIM 01 52Y56			$3\frac{1}{2}$
SRIM 01 52Y60			$3\frac{3}{4}$
SRIM 01 52Y64			4
SRIM 01 52Y72			$4\frac{1}{2}$

DESIGNATION	d	D	L
SRIM 01 52Y76	3 1/4	3 7/16	4 3/4
SRIM 01 52Y80			5
SRIM 01 56Y32			2
SRIM 01 56Y38			2 3/8
SRIM 01 56Y40			2 1/2
SRIM 01 56Y48			3
SRIM 01 56Y56	3 1/2	3 11/16	3 1/2
SRIM 01 56Y60			3 3/4
SRIM 01 56Y64			4
SRIM 01 56Y72			4 1/2
SRIM 01 56Y76			4 3/4
SRIM 01 56Y80			5
SRIM 01 58Y32			2
SRIM 01 58Y36			2 1/4
SRIM 01 58Y40			2 1/2
SRIM 01 58Y48			3
SRIM 01 58Y56	3 5/8	3 13/16	3 1/2
SRIM 01 58Y60			3 3/4
SRIM 01 58Y64			4
SRIM 01 58Y72			4 1/2
SRIM 01 58Y76			4 3/4
SRIM 01 58Y80			5
SRIM 01 60Y32			2
SRIM 01 60Y36			2 1/4
SRIM 01 60Y40			2 1/2
SRIM 01 60Y48			3
SRIM 01 60Y56	3 3/4	3 15/16	3 1/2
SRIM 01 60Y60			3 3/4
SRIM 01 60Y64			4
SRIM 01 60Y72			4 1/2
SRIM 01 60Y76			4 3/4
SRIM 01 60Y80			5
SRIM 01 64Y32			2
SRIM 01 64Y36			2 1/4
SRIM 01 64Y40			2 1/2
SRIM 01 64Y48			3
SRIM 01 64Y56	4	3 3/16	3 1/2
SRIM 01 64Y60			3 3/4
SRIM 01 64Y64			4
SRIM 01 64Y72			4 1/2
SRIM 01 64Y76			4 3/4
SRIM 01 64Y80			5
SRIM 01 68Y32	4 1/4	4 7/16	2
SRIM 01 68Y36			2 1/4

DESIGNATION	d	D	L
SRIM 01 68Y40			2 1/2
SRIM 01 68Y48			3
SRIM 01 68Y56			3 1/2
SRIM 01 68Y60	4 1/4	4 7/16	3 3/4
SRIM 01 68Y64			4
SRIM 01 68Y72			4 1/2
SRIM 01 68Y76			4 3/4
SRIM 01 68Y80			5
SRIM 01 70Y32			2
SRIM 01 70Y36			2 1/4
SRIM 01 70Y40			2 1/2
SRIM 01 70Y48			3
SRIM 01 70Y56	4 3/8	4 9/16	3 1/2
SRIM 01 70Y60			3 3/4
SRIM 01 70Y64			4
SRIM 01 70Y72			4 1/2
SRIM 01 70Y76			4 3/4
SRIM 01 70Y80			5
SRIM 01 72Y32			2
SRIM 01 72Y36			2 1/4
SRIM01 72Y40			2 1/2
SRIM 01 72Y48			3
SRIM 01 72Y56	4 1/2	4 11/16	3 1/2
SRIM 01 72Y60			3 3/4
SRIM 01 72Y64			4
SRIM01 72Y72			4 1/2
SRIM 01 72Y76			4 3/4
SRIM 01 72Y80			5
SRIM 01 76Y32			2
SRIM 01 76Y36			2 1/4
SRIM 01 76Y40			2 1/2
SRIM 01 76Y48			3
SRIM 01 76Y56	4 3/4	4 15/16	3 1/2
SRIM 01 76Y60			3 3/4
SRIM 01 76Y64			4
SRIM 01 76Y72			4 1/2
SRIM 01 76Y76			4 3/4
SRIM 01 76Y80			5
SRIM 01 80Y32			2
SRIM 01 80Y36			2 1/4
SRIM 01 80Y40	5	5 3/16	2 1/2
SRIM 01 80Y48			3
SRIM 01 80Y56			3 1/2
SRIM 01 80Y60			3 3/4

DESIGNATION	d	D	L		
SRIM 01 80Y64	5	5 ³ / ₁₆	4		
SRIM 01 80Y72			4 ¹ / ₂		
SRIM 01 80Y76			4 ³ / ₄		
SRIM 01 80Y80			5		
SRIM 01 84Y32	5 ¹ / ₄	5 ⁷ / ₁₆	2		
SRIM 01 84Y36			2 ¹ / ₄		
SRIM 01 84Y40			2 ¹ / ₂		
SRIM 01 84Y48			3		
SRIM 01 84Y56			3 ¹ / ₂		
SRIM 01 84Y60			3 ³ / ₄		
SRIM 01 84Y64			4		
SRIM 01 84Y72			4 ¹ / ₂		
SRIM 01 84Y76			4 ³ / ₄		
SRIM 01 84Y80			5		
SRIM 01 88Y32			5 ¹ / ₂	5 ¹¹ / ₁₆	2
SRIM 01 88Y36					2 ¹ / ₄
SRIM 01 88Y40	2 ¹ / ₂				
SRIM 01 88Y48	3				
SRIM 01 88Y56	3 ¹ / ₂				
SRIM 01 88Y60	3 ³ / ₄				
SRIM 01 88Y64	4				
SRIM 01 88Y72	4 ¹ / ₂				
SRIM 01 88Y76	4 ³ / ₄				
SRIM 01 88Y80	5				
SRIM 01 92Y32	5 ³ / ₄	5 ¹⁵ / ₁₆			2
SRIM 01 92Y36					2 ¹ / ₄
SRIM 01 92Y40			2 ¹ / ₂		
SRIM 01 92Y48			3		
SRIM 01 92Y56			3 ¹ / ₂		
SRIM 01 92Y60			3 ³ / ₄		
SRIM 01 92Y64			4		
SRIM 01 92Y72			4 ¹ / ₂		
SRIM 01 92Y76			4 ³ / ₄		
SRIM 01 92Y80			5		
SRIM 01 96Y32			6	6 ³ / ₁₆	2
SRIM 01 96Y36					2 ¹ / ₄
SRIM 01 96Y40	2 ¹ / ₂				
SRIM 01 96Y48	3				
SRIM 01 96Y56	3 ¹ / ₂				
SRIM 01 96Y60	3 ³ / ₄				
SRIM 01 96Y64	4				
SRIM 01 96Y72	4 ¹ / ₂				

DESIGNATION	d	D	L		
SRIM 01 96Y76	6	6 ³ / ₁₆	4 ³ / ₄		
SRIM 01 96Y80			5		
SRIM 01 100Y32	6 ¹ / ₄	6 ⁷ / ₁₆	2		
SRIM 01 100Y36			2 ¹ / ₄		
SRIM 01 100Y40			2 ¹ / ₂		
SRIM 01 100Y48			3		
SRIM 01 100Y56			3 ¹ / ₂		
SRIM 01 100Y60			3 ³ / ₄		
SRIM 01 100Y64			4		
SRIM 01 100Y72			4 ¹ / ₂		
SRIM 01 100Y76			4 ³ / ₄		
SRIM 01 100Y80			5		
SRIM 01 104Y32			6 ¹ / ₂	6 ¹¹ / ₁₆	2
SRIM 01 104Y36					2 ¹ / ₄
SRIM 01 104Y40	2 ¹ / ₂				
SRIM 01 104Y48	3				
SRIM 01 104Y56	3 ¹ / ₂				
SRIM 01 104Y60	3 ³ / ₄				
SRIM 01 104Y64	4				
SRIM 01 104Y72	4 ¹ / ₂				
SRIM 01 104Y76	4 ³ / ₄				
SRIM 01 104Y80	5				
SRIM 01 108Y32	6 ³ / ₄	6 ¹⁵ / ₁₆			2
SRIM 01 108Y36					2 ¹ / ₄
SRIM 01 108Y40			2 ¹ / ₂		
SRIM 01 108Y48			3		
SRIM 01 108Y56			3 ¹ / ₂		
SRIM 01 108Y60			3 ³ / ₄		
SRIM 01 108Y64			4		
SRIM 01 108Y72			4 ¹ / ₂		
SRIM 01 108Y76			4 ³ / ₄		
SRIM 01 108Y80			5		
SRIM 01 112Y32			7	7 ³ / ₁₆	2
SRIM 01 112Y36					2 ¹ / ₄
SRIM 01 112Y40	2 ¹ / ₂				
SRIM 01 112Y48	3				
SRIM 01 112Y56	3 ¹ / ₂				
SRIM 01 112Y60	3 ³ / ₄				
SRIM 01 112Y64	4				
SRIM 01 112Y72	4 ¹ / ₂				
SRIM 01 112Y76	4 ³ / ₄				
SRIM 01 112Y80	5				

SUITABLE SHAFT, HOUSING BORE TOLERANCE TABLE

BASIC DIMENSION d	SUITABLE HOUSING BORE DH	SUITABLE SHAFT dj
3/8	0.4684 0.4691	0.3750 0.3740
1/2	0.5934 0.5941	0.5000 0.4990
5/8	0.7184 0.7192	0.6250 0.6240
3/4	0.8747 0.8755	0.7500 0.7488
7/8	0.9997 1.0005	0.8750 0.8738

BASIC DIMENSION d	SUITABLE HOUSING BORE DH	SUITABLE SHAFT dj
1	1.1246 1.1256	1.0000 0.9988
1 1/4	1.4058 1.4068	1.2500 1.2484
1 1/2	1.6558 1.6568	1.5000 1.4984
1 3/4	1.9371 1.9381	1.7500 1.7484

WALL THICKNESS TOLERANCES AND INSIDE, OUTSIDE CHAMFER TABLE

BASIC DIMENSION d	WALL THICKNESS TOLERANCES S _B	CHAMFER DIMENSION	
		f1	f2
3/8 - 5/8	0.052 0.044	0.0394 0.0079	Max.0.0157
5/8 - 1	0.068 0.060	0.0394 0.0079	0.0079 0.0039
1 - 1 1/2	0.083 0.075	0.0630 0.0315	0.0276 0.0039
1 1/2 - 1 3/4	0.098 0.090	0.0945 0.0472	0.0394 0.0079

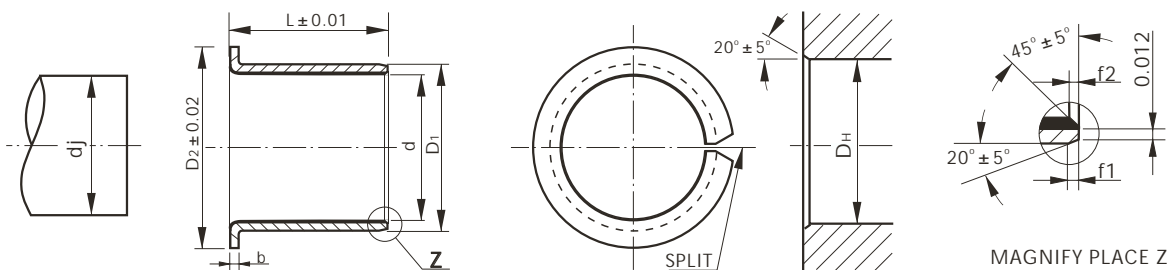

Unit:inch

DESIGNATION	d	D ₁	D ₂	L
SRIM 01 F 06 Y 04				1/4
SRIM 01 F 06 Y 06	3/8	15/32	11/16	3/8
SRIM 01 F 06 Y 08				1/2
SRIM 01 F 06 Y 12				3/4
SRIM 01 F 08 Y 04				1/4
SRIM 01 F 08 Y 06	1/2	19/32	13/16	3/8
SRIM 01 F 08 Y 08				1/2
SRIM 01 F 08 Y 12				3/4
SRIM 01 F 10 Y 06				3/8
SRIM 01 F 10 Y 08	5/8	23/32	15/16	1/2
SRIM 01 F 10 Y 10				5/8
SRIM 01 F 10 Y 12				3/4
SRIM 01 F 12 Y 06				3/8
SRIM 01 F 12 Y 08	3/4	7/8	1 1/8	1/2
SRIM 01 F 12 Y 12				3/4
SRIM 01 F 12 Y 16				1
SRIM 01 F 14 Y 08	7/8	1	1 1/4	1/2

DESIGNATION	d	D ₁	D ₂	L
SRIM 01 F 14 Y 12				3/4
SRIM 01 F 14 Y 16	7/8	1	1 1/4	1
SRIM 01 F 14 Y 20				1 1/4
SRIM 01 F 16 Y 08				1/2
SRIM 01 F 16 Y 12	1	1 1/8	1 3/8	3/4
SRIM 01 F 16 Y 16				1
SRIM 01 F 16 Y 20				1 1/4
SRIM 01 F 20 Y 16				1
SRIM 01 F 20 Y 20	1 1/4	1 13/32	1 3/4	1 1/4
SRIM 01 F 20 Y 24				1 1/2
SRIM 01 F 24 Y 16				1
SRIM 01 F 24 Y 24	1 1/2	1 21/32	2	1 1/2
SRIM 01 F 24 Y 32				2
SRIM 01 F 28 Y 16				1
SRIM 01 F 28 Y 24	2 3/4	2 15/16	2 3/8	1 1/2
SRIM 01 F 28 Y 32				2

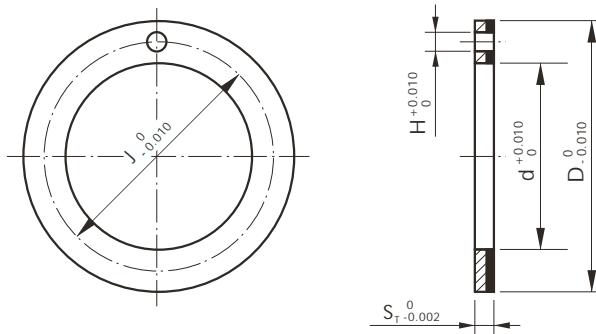

Unit:inch

DESIGNATION	$d_0^{+0.01}$	$D_0^{-0.01}$	$J_0^{-0.01}$	$h_0^{+0.01}$	$S_T_0^{-0.002}$
SRIM 01 W Y 06	0.500	0.875	0.692	0.067	
SRIM 01 W Y 07	0.562	1.000	0.786		
SRIM 01 W Y 08	0.625	1.125	0.880		
SRIM 01 W Y 09	0.678	1.187	0.942	0.099	
SRIM 01 W Y 10	0.750	1.250	1.005		
SRIM 01 W Y 11	0.812	1.375	1.099		
SRIM 01 W Y 12	0.875	1.500	1.192	0.130	0.063
SRIM 01 W Y 14	1.000	1.750	1.380		
SRIM 01 W Y 16	1.125	2.000	1.576		
SRIM 01 W Y 18	1.250	2.125	1.692	0.161	
SRIM 01 W Y 20	1.375	2.250	1.817		
SRIM 01 W Y 22	1.500	2.500	2.005		
SRIM 01 W Y 24	1.625	2.625	2.130	0.192	
SRIM 01 W Y 26	1.750	2.750	2.255		
SRIM 01 W Y 28	2.000	3.000	2.505		
SRIM 01 W Y 30	2.125	3.125	2.630	0.093	
SRIM 01 W Y 32	2.250	3.250	2.755		